



## **APPLICATION DATA SHEET**

### **TILTED-DISC® CHECK VALVE FOR PUMP DISCHARGE**

#### **DESCRIPTION OF APPLICATION**

Peoria Heights is located on a bluff overlooking the Mississippi River in Central Illinois. Water is pumped from five 200 foot riverside wells to a 300,000 gallon standpipe where it is chemically treated. An unmanned pump station lifts the water 260 ft. through a 1 mile long, 16" diameter pipeline to a ground storage reservoir up on the bluff. The pump station has been in operation for many years with pilot operated pump control valves.

Tilted-Disc® Check Valves are being used to replace existing globe-style control valves. The control valves were equipped with pilots and needle valves which were difficult to maintain. Because of a failure of the control valve limit switch, one pump required rebuilding after it ran against a closed valve for several hours. The Tilted-Disc® valves were also selected for their low headloss and resultant energy savings.

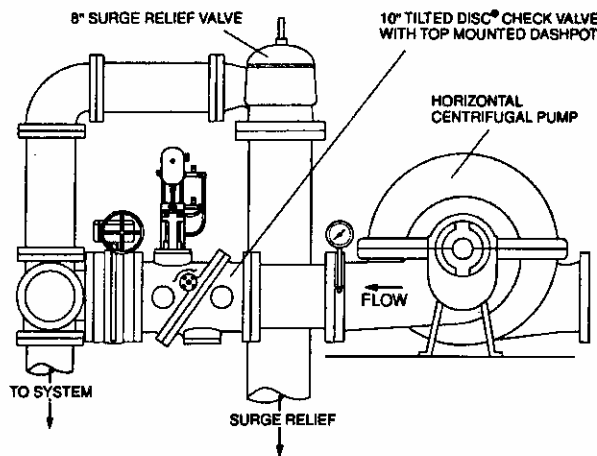

#### **PEORIA HEIGHTS, IL BOOSTER STATION**

#### **OPERATING DATA**

Valve Size:	10" W/Top Mounted Dashpot
Total Static Head:	175 ft.
Flow Rate:	7.2 ft per sec.
Pump Operation:	Multiple
Surge Relief:	Anticipator Valve
Line Length:	5000 ft. of 16" Cast Iron

#### **VAL-MATIC® EQUIPMENT:**

**TILTED-DISC® CHECK VALVE:** Each pump is equipped with a 10"-250# Class Tilted-Disc® Check Valve to prevent reverse flow. The Tilted-Disc® with top mounted oil dashpot was specified to obtain the lowest possible headloss and reduce surges.

The valves are fully automatic and require no power or connection to the pump controls to operate. The valves feature stable operation, rugged ductile iron construction, and a gall-free aluminum-bronze seat.

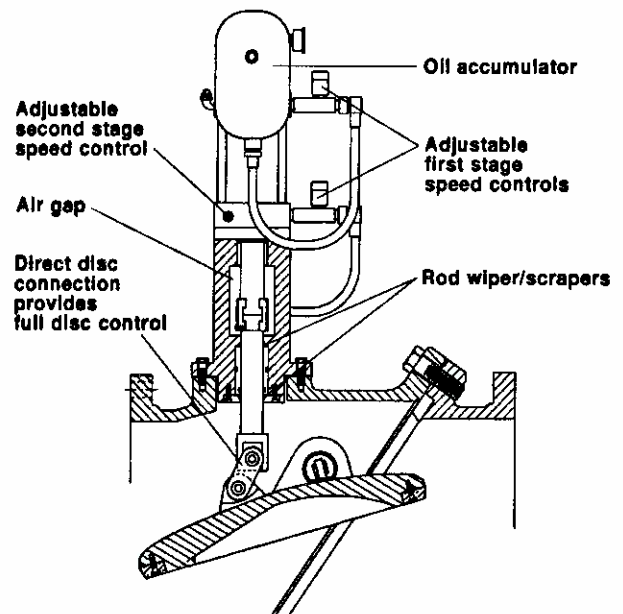

#### **TILTED-DISC® CHECK VALVE**

The top mounted oil dashpot controls the valve opening and closing stroke to reduce the potential for surges. The dashpot includes mechanical linkage between the disc and a 3000 psi hydraulic cylinder. The hydraulic cylinder is fitted with speed control valves to control the opening and closing rates. The controls are set to open and close the valve in about 5 seconds to reduce surges and prevent reverse flow through the pump.

The valves work in concert with a surge anticipator valve mounted on the discharge header. When a high or low pressure is sensed, the valve rapidly opens to relieve water back to the standpipe.

## **TILTED-DISC® CHECK VALVE FOR PUMP DISCHARGE**

### **DESCRIPTION OF OPERATION**

Four pumps deliver water from a standpipe to a 16" pipeline at 130 psig with a 35 psig suction pressure. Only one pump is operated at a time as follows.

1. The pump motor is powered and after a 3 minute time delay, starts and develops 130 psig pressure in the discharge piping.
2. The rising discharge pressure exerts an opening force on the check valve disc.
3. An upward force is exerted on the hydraulic cylinder rod which is resisted by the oil above the cylinder piston. The oil is slowly relieved through the top speed control valve into the bottom of the oil accumulator.
4. The valve opens in about 5 seconds.
5. The pump delivers 1750 GPM or 7.2 fps through the check valve and a 10" manual butterfly valve into the 16" header.
6. After the pump is stopped, the reverse flow pushes the disc closed which exerts a downward force on the cylinder rod. The oil below the cylinder piston becomes pressurized and is relieved by the lower speed control valve.
7. The valve closes 90% then the cylinder rod engages an internal cylinder cushion which slows down the closing rate further for the final 10% of travel. The pump and valve are now ready for another operating sequence.

### **SURGE CONTROL**

Surges are caused by the sudden change in flow velocity within the critical time after pump stoppage. The critical time is the period for a pressure wave to travel the length of the system and return and is calculated by the following equation.

$$T = \frac{2L}{a}$$

Where:  
 T = critical time, sec.  
 L = length of line, ft.  
 a = wave velocity, ft/sec

For 16" iron pipe, the wave velocity is 3000 ft/sec. The critical time for the 5000 ft. length is 3.3 seconds which corresponded to the field observed upsurge delay. The maximum surge pressure is related to the initial velocity in the 16" pipe (1750 gpm or 2.8 ft/sec) and can be found by:

$$h = \frac{av}{g}$$

Where:  
 h = pressure rise, ft of water  
 v = change in velocity, ft/sec  
 a = wave velocity, ft/sec  
 g = gravity, 32.2 ft/sec<sup>2</sup>

The computed maximum upsurge is 260 ft or 113 psi. The observed surge pressure was about 75 psi which diminished down to zero in five peaks over a 20 second period.

### **ENERGY CALCULATIONS**

The Tilted-Disc® Check Valve was specified for this application to provide low energy consumption. The equation for calculating the yearly energy costs based on 100% usage is as follows:

$$ECS/Y = \frac{GPM \times HLD \times S_g \times C/Kwh \times 1.65}{PE \times ME}$$

Where:  
 ECS/Y = yearly energy cost, \$  
 GPM = flow rate, gal/min  
 HLD = head loss, ft of water  
 S<sub>g</sub> = specific gravity, (water = 1.0)  
 C/Kwh = cost of electricity, \$/Kw-hour  
 PE,ME = Pump, Motor efficiency, (.85 typ)

Based on 1750 GPM, 0.6 ft of water, and \$.08 per Kwh, the annual energy cost is \$192. The energy cost for the pilot operated control valve with a head loss of 4.6 ft is \$1470 per year. The savings over 40 years based on 25% usage is over \$12,800. The Tilted-Disc® Check Valve was an excellent choice for this application.

