



## APPLICATION ENGINEERING GUIDE

### TILTED-DISC® CHECK VALVE PUMP DISCHARGE SERVICE

#### INTRODUCTION

The purpose of this guide is to provide background information on pump discharge applications and recommendations for specifying and installing Tilted-Disc® Check Valves. The valve is energy efficient and provides non-slam closing by utilizing a short disc stroke of 40°. The energy savings produced by the streamline body and hydrodynamically designed disc make it an excellent choice for pump discharge applications. The valve will pay for itself many times over in ease of maintenance and energy savings.

#### DESCRIPTION OF VALVE

Val-Matic®'s Tilted-Disc® Check Valve is a rugged valve with excellent head loss characteristics. The valve is ideally suited for raw water, cooling water, and treated water/wastewater applications. The valve's tapered metal seats are constructed of wear-resistant alloys and provide tight seating and long life even in the most severe applications. The operation of the valve is self contained and fully automatic.

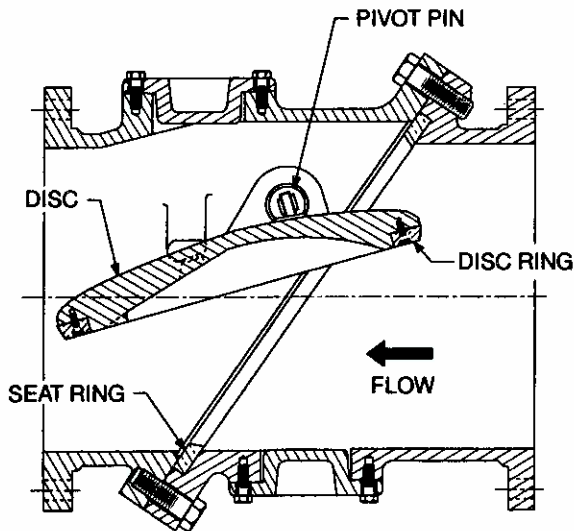

#### TILTED-DISC® CHECK VALVE CONSTRUCTION

The valve can be equipped with bottom or top mounted oil dashpots for various applications. The bottom dashpot controls the last 10% of valve closure with a hydraulic cylinder. The top mounted dashpot also independently controls the full opening and closing strokes to reduce surges on longer systems.

#### VALVE FUNCTION

In pump discharge service, the valve must open wide during pumping and close tightly after pump shutdown to prevent reverse flow. To prevent slam during pump shutdown, the valve should either close rapidly before flow reversal or with the use of dashpots, close slowly to provide soft seating action. Controlled opening and closing strokes are available to reduce the potential for surges during operation.

The headloss across any valve in feet of water column is easily computed using the equation:

$$H = 2.31 \left( \frac{Q}{C_v} \right)^2 S_g$$

Where:

- H = head loss, ft.
- Q = flow rate, gal/min
- Cv = valve flow coefficient
- Sg = specific gravity

#### SURGE CONTROL

Sudden changes in flow velocity will cause a pressure surge or "water hammer" in a piping system which can damage equipment. For example, if a flow of 8 ft/sec is suddenly introduced or stopped in a pipeline, a surge pressure as high as 400 psi above the static pressure may be produced.

On long systems, the change in velocity produces a pressure wave which travels at the speed of sound in water from one end to the system to the other. The elapsed time is called the **critical time**.

*Any change in flow velocity that occurs within the Critical Time has the same effect as if the change occurred instantaneously!*

For example, on a 5000 feet steel pipe, the critical time is about 3.3 seconds. Hence, a flow stoppage within 3.3 seconds will produce the same surge as if the flow was stopped instantaneously. As a rule of thumb, the magnitude of the surge is typically 50 psi for every 1 ft/sec of velocity change. Because of this principle, long systems require careful analysis and are usually computer modeled. Most systems greater than 3000 feet will have a surge protection system and possibly a control valve set to open and close very slowly, typically 5-10 times the critical time.

## **TILTED DISC® CHECK VALVE PUMP DISCHARGE SERVICE**

### **SINGLE PUMP SYSTEM**

A single pump system or one where only one pump is operated at a time is illustrated in schematic form below. Tilted-Disc® Check Valves are commonly used with both centrifugal and vertical turbine pumps which produce flow rates in the range of 4-18 feet per second and pressures to 300 psig. The water level on the suction side of the pump can be either above or below the pump as shown.

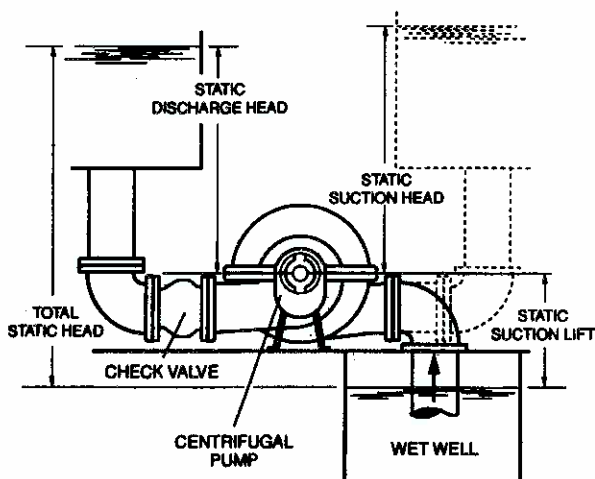

### **PUMP SYSTEM TERMS**

The total static head and the system resistance (friction) are used to determine the severity of an application. When the static head is high and the system resistance low, the system will have rapid flow reversal when the pump is stopped. Conversely, on low head systems with high resistance, the flow reversal may take several seconds.

On longer systems, the changes in velocity from starting and stopping pumps can cause surges which are relieved with the use of surge relief valves mounted on the discharge header. These valves typically sense the high and/or low pressure fluctuations and open to relieve water back to the wet well. On more severe applications, surge tanks are employed.

### **MULTIPLE PUMP SYSTEM**

Multiple pump systems are often used to help reduce surges, provide high system capacity, and provide for varying output flows to meet water demand. Surges

are reduced in a multiple pump system because the pumps are started and stopped one at a time. The pumps therefore have a much smaller impact on the velocity changes in the main header. Also, by running a different quantity of pumps or different combinations of pumps, varying output flows can be produced.

Depending on the system pressure, the check valves may need a dashpot because parallel pumps cause a rapid reversal of flow after shutdown. It should also be noted that after a power failure, the pumps stop simultaneously and cause a significant change in the pipeline velocity. For this reason, most multiple pump installations will have surge relief valves or a surge tank.

### **CLOSED SURGE TANK APPLICATIONS**

A common type of surge tank is called a hydro-pneumatic tank because it is filled with both water and compressed air. The tank is connected to the

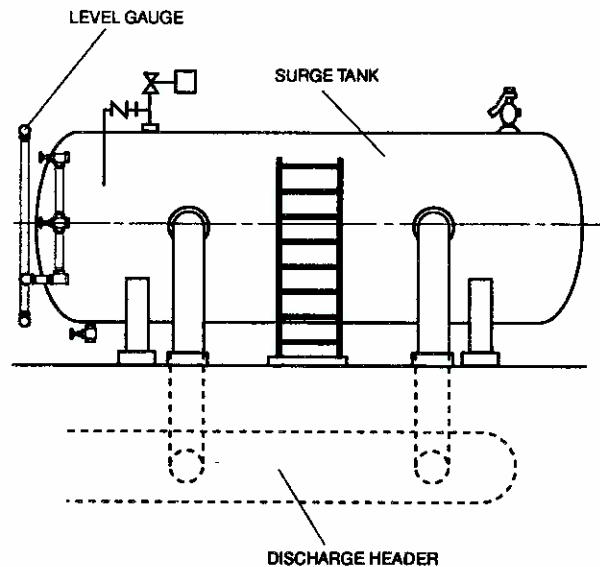

### **HYDROPNEUMATIC SURGE TANK INSTALLATION**

discharge header. After pump shutdown or power failure, the tank forces water into the line to prevent column separation. A few seconds later, an upsurge occurs and water re-enters the tank dissipating the surge. Because sizing of the tank is critical to its operation, the check valve must close rapidly to prevent reverse flow through the pump after pump stoppage. Also, the surge tank pressure causes a rapid reversal of flow back toward the pump which may slam the check valve. When used with surge tanks, check valves require a bottom mounted oil dashpot which will allow the valve to rapidly close, yet prevent slamming.

## **TILTED DISC® CHECK VALVE PUMP DISCHARGE SERVICE**

### **APPLICATION CRITERIA**

The general operating parameters for the valve are summarized in the table below. A comprehensive presentation of features and dimensions is presented in Val-Matic® Bulletin 9000.

#### **STANDARD OPERATING PARAMETERS**

<b>PARAMETER</b>	<b>TYP. RANGE OF USE</b>
SIZE RANGE	2" - 60"
PRES CLASSES	125#, 150#, 250#
MAX TEMPERATURE	250°F
FLOW RANGE	4-18 FPS
ORIENTATION	HORIZ OR VERTICAL
CONNECTION	FLANGED: ANSI, ISO

The valve is versatile and can be used in more demanding applications with the use of special materials of construction upon request. The Tilted-Disc® Check Valve is available in three configurations:

- **Basic Valve**
- **Bottom Mounted Oil Dashpot**
- **Top Mounted Oil Dashpot.**

It is important to note that the dashpot configurations include high pressure oil cylinders and full rated disc connections. With oil dashpots, the disc is rigidly controlled as opposed to an air cushion which only produces a mild damping effect.

To select the proper valve configuration, several criteria must be considered. The **number of pumps** and the **static head** will affect how rapidly the water column will reverse when a pump is stopped. The **type of pump control** will effect the required closing characteristic of the valve. Typical types of control include on-off, soft-start, variable speed, and electrically operated control valves. The **length** of the piping system is used to estimate surges from changes in flow velocity. The type of **surge relief system** dictates the required closing time for the valve. Surge tanks require a quick-closing valve to prevent the loss of stored water back through the pump. The criteria listed above are used to select the best valve configuration as follows.

### **1. BASIC VALVE**

The basic valve features a short stroke angle of 40° which provides rapid disc closure in less than ½ second. This feature will provide non-slam closure in low service pumping applications. Basic valves are typically used when the static head is less than 100

feet in single or multiple pump applications. A common application is the filter backwash pumps in a water treatment plant.

### **2. BOTTOM MOUNTED OIL DASHPOT**

Dashpots are used on high service pumping applications where there is a propensity for rapid flow reversal. The dashpot consists of a hydraulic cylinder and a snubber rod which contacts the disc during closing. A spring and air/oil reservoir are used to provide return force to the snubber rod and oil for the opening stroke to makeup for the cylinder rod volume. The dashpot controls the last 10% of valve closure to reduce water hammer and prevent slamming of the disc.

The valve is effective on shorter length systems with static heads up to the valve rating. The dashpot is also used on longer systems where rapid flow reversal occurs due to the use of surge tanks or in multiple pump systems. The dashpot is field adjustable and typically set to control the last 10% of closure in 1-5 seconds. A greater closure time may produce excessive reverse flow through the pump.

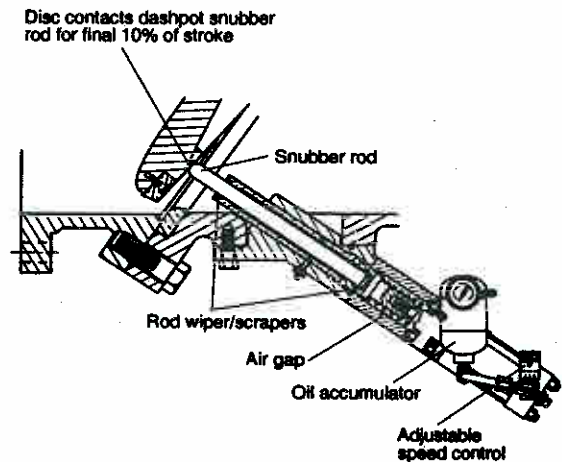

**BOTTOM MOUNTED OIL DASHPOT**

### **3. TOP MOUNTED OIL DASHPOT**

The top mounted oil dashpot controls both the full opening and full closing stroke of the valve. Also, the last 10% of travel of valve closure is independently controlled by an adjustable hydraulic cylinder cushion. With the top mounted oil dashpot, the disc is mechanically linked to a hydraulic cylinder equipped with flow control valves. The high pressure hydraulic cylinder and linkage is designed to withstand the full thrust of the disc when subjected to line pressure. An air/oil reservoir is used to provide return force to the linkage rod and oil for the opening stroke to makeup for the cylinder rod volume.

## **TILTED DISC® CHECK VALVE PUMP DISCHARGE SERVICE**

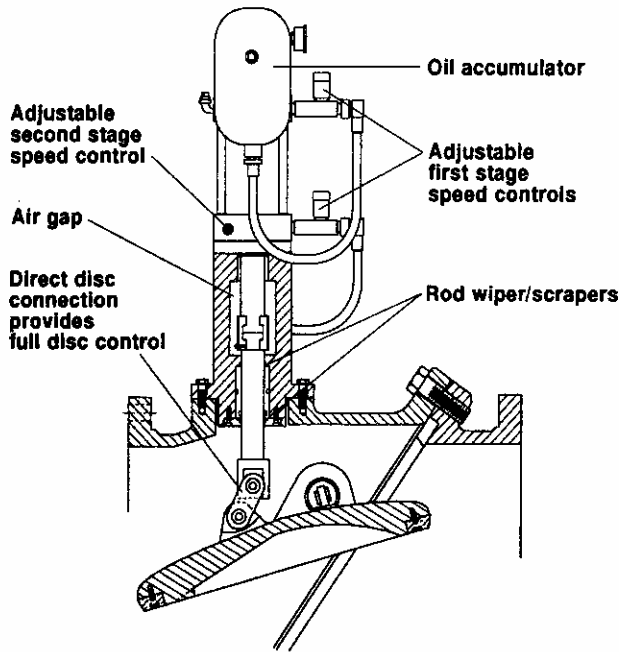

**TOP MOUNTED OIL DASHPOT**

Valves equipped with top mounted oil dashpots have been used in extreme service applications up to the full flow and pressure rating of the valve. When there is insufficient space to provide a straight run of pipe between the pump and the valve, the top mounted dashpot will control the disc movement and prolong the life of the valve.

The opening and closing strokes are field adjustable in the 5-30 second range. A greater closure time may produce excessive reverse flow through the pump. The final 10% of closure is adjustable in the 1-5 second range to prevent slam.

By setting the valve opening time to 20 seconds, the system flow rate will rise to 50% in about 2 seconds which equates to the critical time period of a system 3000 feet in length. On longer systems, the dashpot will not have an appreciable effect on pressure surges; therefore, a surge analysis and surge equipment are recommended.

On very long systems, a power operated control valve is sometimes used. The control valve is electrically

wired to the pump control and is programmed to slowly open and close to gradually change the flow rate in the system over a 60-300 second period. However, after a power outage, the control valve may not be capable of closing rapidly enough to prevent back spinning of the pump or loss of water from a surge tank. In these cases a Tilted-Disc® is often installed upstream of the control valve.

### **INSTALLATION GUIDELINES**

To ensure proper operation of the valve, several guidelines should be followed in the piping design.

1. The basic valve can be installed in both horizontal or vertical flow-up runs. Valves in raw water service should be installed in horizontal runs to prevent debris from collecting on the disc.
2. The valve should be the same size as the discharge line and located a minimum of three straight pipe diameters from the pump or an elbow.
3. An isolation valve such as an eccentric plug valve or butterfly valve should be installed downstream for servicing the pump and check valve. Butterfly valves should be located one diameter downstream to prevent disc interference.
4. Options include special materials for corrosive service, limit switches for remote valve indication, and bypass ports for backflushing suction lines.

### **ENERGY CALCULATIONS**

One of the primary reasons for selecting Tilted Disc® Check Valves for pump discharge is to obtain low energy consumption. The equation for calculating the yearly energy costs based on 100% usage is as follows:

$$EC/Y = \frac{GPM \times HL \times S_g \times C/Kwh \times 1.65}{PE \times ME}$$

Where:

EC/Y	= energy costs per year, \$/year
GPM	= flow rate, gal/min
HL	= head loss, ft of water
S <sub>g</sub>	= specific gravity, (water = 1.0)
C/Kwh	= cost of electricity, \$/Kw-hour
PE	= Pump efficiency, (.85 typ)
ME	= Motor efficiency, (.85 typ)

For a system operating less than 24 hours per day, multiply the energy costs by an appropriate percentage. The equation can also be used to compare operating costs between two types of valves by using their corresponding head losses (HL).

# **TILTED DISC® CHECK VALVE** **PUMP DISCHARGE SERVICE**

## **CASE IN POINT**

The Aurora, Illinois Water Treatment Plant has six multiple pumps installed above a clear well to deliver 3200 GPM at 60 psig. The pumps are equipped with 12"-125# Tilted-Disc® Check Valves without dashpots. The valves discharge into a 30" main header equipped with a 4" surge relief valve.

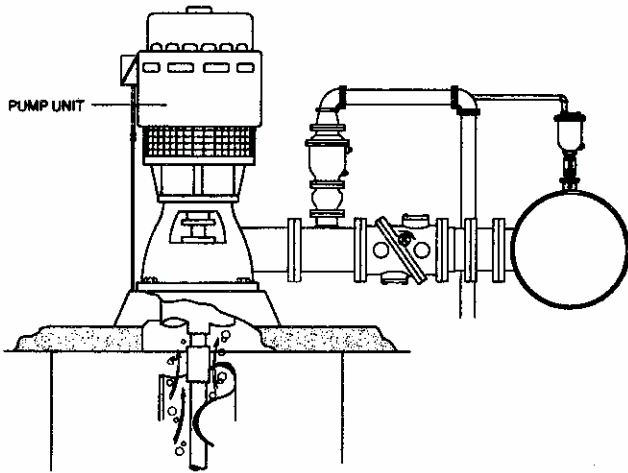

**12" Tilted-Disc® at Aurora, IL**

The Tilted-Disc® Check Valve has a headloss of 0.7 feet of water column under these conditions. Based on an energy cost of \$.08 per KWhr, the annual energy cost is \$409. The energy cost for a pilot operated control valve with a head loss of 2.9 ft would be \$1695 per year. The savings for all 6 pumps over 40 years based on 50% usage would be about \$154,320. The Tilted-Disc® Check Valve was an excellent choice for this application.

## **SUMMARY**

General recommendations for Tilted-Disc® Check Valves are based on the following parameters:

1. **Type of Installation:** A multiple pump installation will cause more rapid flow reversal.
2. **Length:** Sudden changes in flow velocity will cause surges in longer lines.
3. **Static Head:** This is the no flow pressure across the check valve. A high static head is an indication of a long system or a steep uphill system where rapid flow reversal may occur.
4. **Surge Relief System:** Common types are relief valves, surge tanks, or slow travel control valves.

For pipelines with velocities greater than 10 feet per second and lengths exceeding 3000 feet, a water hammer or transient analysis should be conducted to determine the performance of the pump and valves together in controlling surges.

The following chart and graph present general guidelines for valve selection. Consult your Val-Matic® sales representative for specific applications.

## **REFERENCES**

1. American Water Works Association, AWWA M11 "Steel Pipe - A Guide for Design & Installation"; 3rd ed., 1989, pp 51-56.
2. Ballun, J. V. "Surge Control In Piping Systems", 1987 Annual Conference Proceedings, AWWA 1987, p. 1663-1674.
3. Tullis, J. Paul. Hydraulics of Pipelines, John Wiley & Sons, New York, 1989.

### **RECOMMENDATIONS FOR APPLICATION OF VAL-MATIC TILTED-DISC® CHECK VALVES**

<b>Type of Installation</b>	<b>Length</b>	<b>Static Head</b>	<b>Surge Relief System</b>	<b>Recommended Check Valve</b>
Single Pump	0-1000 ft.	0-100 ft.	NONE	Basic Valve
Multiple Pump	0-1000 ft.	0-100 ft.	NONE	Basic Valve
Single/Multiple Pump	0-1000 ft.	>100 ft.	NONE	Valve W/Bottom Oil Dashpot
Single/Multiple Pump	0-3000 ft.	0-200 ft.	NONE	Valve W/Top Oil Dashpot
Single/Multiple Pump	0-3000 ft.	0-200 ft.	Relief Valve/Surge Tank	Valve W/Bottom Oil Dashpot
Single/Multiple Pump	0-3000 ft.	>200 ft.	Relief Valve	Valve W/Top Oil Dashpot
Single/Multiple Pump	>3000 ft.	>50 ft.	Relief Valve	Valve W/Top Oil Dashpot
Single/Multiple Pump	>3000 ft.	>50 ft.	Surge Tank/Control Valve	Valve W/Bottom Oil Dashpot

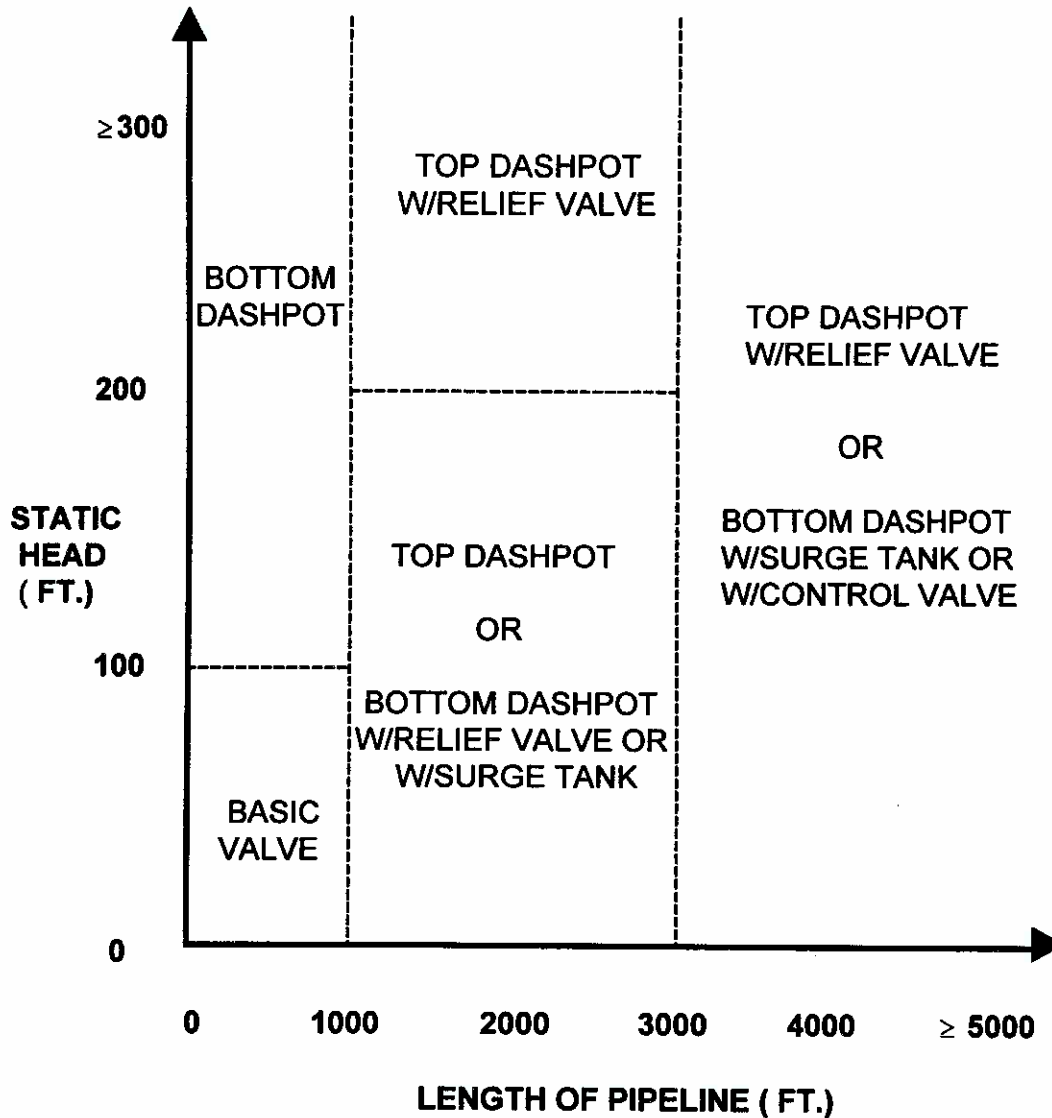

### TILTED DISC® CHECK VALVE APPLICATION GRAPH

The application graph illustrates the range of use for three valve configurations: 1) basic valve, 2) bottom mounted oil dashpot, and 3) top mounted oil dashpot. For example, on a 2500 ft. long water transmission main operating at 150 ft. of head, a Tilted-Disc® Check Valve with a top mounted oil dashpot would be selected. Or, if a surge relief system is provided, then the bottom mounted oil dashpot configuration can be used. Consult Val-Matic® Bulletin 9000 or your sales representative for specific check valve model numbers and pricing.